



MODEL
SFT-1200

CATEGORY
Exhaust

DESCRIPTION
12" direct-drive shutter fan.

FEATURES

- Rugged corrosion-proof PVC shutter and powder-coated (over zinc coating) guard.
- Aluminum fan blade.
- Totally enclosed, maintenance free, energy efficient motor.

DIMENSIONS

Model	A	B	C	D	E	F	G	H
SFT-1200	14 ⁷ / ₈ "	14 ⁷ / ₈ "	12 ¹ / ₈ "	12 ¹ / ₈ "	3"	3 ⁷ / ₈ "	1 ¹ / ₈ "	1 ³ / ₄ "

Rough-in Opening 12⁵/₈" x 12⁵/₈"

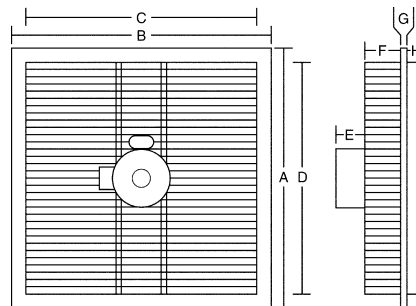

PERFORMANCE

760 CFM at .05 static pressure

MOTOR

Model	HP	Type	Voltage	Amps	RPM
CS130	1/30	TEAO	115	0.90	1550

BLADE

Model	Type	Wings	Bore Size	Pitch
AFB-104SF	Aluminum	4	5/16"	

SHIPPING

Weight	Box Dimension	UPS	Pallet Quantity
12 lbs	19 x 18 x 10	Yes	24 or 26

Test data, performance, energy consumption and other specifications are based on results in a controlled environment. Actual results will vary. Product specifications subject to change.



800-779-3267 • Fax: 320-251-2922
sales@schaeferfan.com • www.schaeferfan.com



MODEL
SFT-1600

CATEGORY
Exhaust

DESCRIPTION
16" direct-drive shutter fan.

FEATURES

- Rugged corrosion-proof PVC shutter and powder-coated (over zinc coating) guard.
- Aluminum fan blade.
- Totally enclosed, maintenance free, energy efficient motor.

DIMENSIONS

Model	A	B	C	D	E	F	G	H
SFT-1600	18 ³ / ₄ "	18 ³ / ₄ "	16"	16"	6"	4 ¹ / ₂ "	1 ¹ / ₈ "	1 ³ / ₄ "

Rough-in Opening 16⁵/₈" x 16⁵/₈"

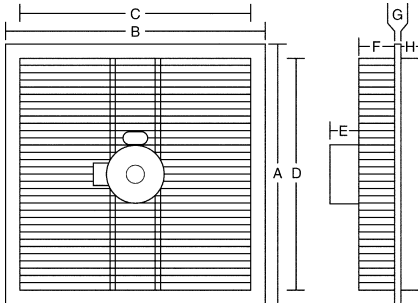

PERFORMANCE

1250 CFM at .05 static pressure

MOTOR

Model	HP	Type	Voltage	Amps	RPM
CS110	1/10	TEAO	115 / 230	1.3 / .65	1725

BLADE

Model	Type	Wings	Bore Size	Pitch
AFB-144SF	Aluminum	4	1/2"	

SHIPPING

Weight	Box Dimension	UPS	Pallet Quantity
21 lbs	22 x 22 x 14	Yes	20

Test data, performance, energy consumption and other specifications are based on results in a controlled environment. Actual results will vary. Product specifications subject to change.



800-779-3267 • Fax: 320-251-2922
sales@schaefervent.com • www.schaefervent.com



MODEL
SFT-2000

CATEGORY
Exhaust

DESCRIPTION
20" direct-drive shutter fan.

FEATURES

- Rugged corrosion-proof PVC shutter and powder-coated (over zinc coating) guard.
- Aluminum fan blade.
- Totally enclosed, maintenance free, energy efficient motor.

DIMENSIONS

Model	A	B	C	D	E	F	G	H
SFT-2000	22 ³ / ₄ "	22 ³ / ₄ "	20"	20"	6"	4 ¹ / ₂ "	1/ ₈ "	1 ³ / ₄ "

Rough-in Opening 20⁵/₈" x 20⁵/₈"

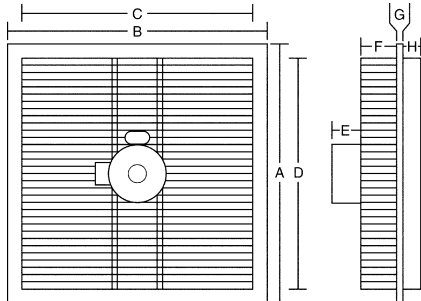

PERFORMANCE

3122 CFM at .05 static pressure

MOTOR

Model	HP	Type	Voltage	Amps	RPM
CS103	1/3	TEAO	115 / 230	3.8 / 1.9	1725

BLADE

Model	Type	Wings	Bore Size	Pitch
AFB-184SF	Aluminum	3	1/2"	

SHIPPING

Weight	Box Dimension	UPS	Pallet Quantity
31 lbs	27 x 26 x 16	Yes	16

Test data, performance, energy consumption and other specifications are based on results in a controlled environment. Actual results will vary. Product specifications subject to change.



800-779-3267 • Fax: 320-251-2922
sales@schaeferfan.com • www.schaeferfan.com